

CLOSED TOP

Fermenting Cider Tank

Ferment, Store, Blend, Bottle

Size	Price Ranges	Minimum Ceiling Height (ft.)	Space Required (sq. ft.)
10 BBL (310 Gal)	\$6,820 - \$8,250	9'	16 - 25
15 BBL (465 Gal)	\$7,920 - \$9,680	10'	18 - 28
20 BBL (620 Gal)	\$8,800 - \$10,670	11'	20 - 30
30 BBL (930 Gal)	\$10,340 - \$12,650	12'	25 - 36
40 BBL (1,240 Gal)	\$11,220 - \$13,640	13'	30 - 42
100 BBL (3,100 Gal)	\$17,050 - \$20,900	17'	52 - 68
200 BBL (6,200 Gal)	\$23,100 - \$28,270	21'	76 - 95

TANK CONFIGURATION

304 polished s/s
ID/OD Buffed Finish
Sloped Bottom
Truncated Top
20" Top Outswing Door
Split RSW Jacketing
Temperature Well
1" Sample Valve
1.5" Racking Port
1.5" Drain

TANK OPTIONS

16"x22" Racking Door \$1025
Pressure Relief Valve \$270
Rotating Racking Arm \$265
2" Butterfly Valve \$169
1.5" Butterfly Valve \$141
Sample Valve \$124
Dial Thermometer \$56
TC Clamp \$9
TC Gasket, set of (2) \$1

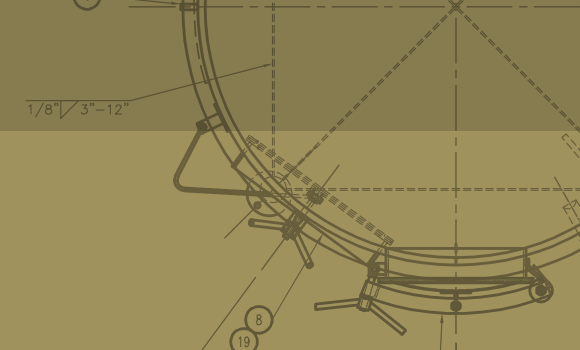

200 BBL Closed Top Cider Tanks; photo courtesy of 2 Towns Cider House